



Alfa Laval SaniJet 25

The only EHEDG certified Rotary Jet Head on the market

Application

The Toftejorg SaniJet 25 rotary jet head provides 3D indexed impact cleaning over a defined time period. It is automatic and represents a guaranteed means of achieving quality assurance in tank cleaning. Used in food and dairy processes industries, the device is suitable for processing, mixing and storage tanks/vessels between 15 and 150 m³. The design is particularly suitable for ultra-hygienic industries that follow European Hygienic Engineering & Design Group Guidelines.

Working principle

The flow of the cleaning fluid makes the nozzles perform a geared rotation around the vertical and horizontal axes. In the first cycle, the nozzles lay out a coarse pattern on the tank surface. The subsequent cycles gradually make the pattern more dense, until a full pattern is reached after 8 cycles.



TECHNICAL DATA

Lubricant: Self-lubricating with the cleaning fluid
 Standard Surface finish: Ra 0.5µm exterior / Ra 0.8µm internal
 Max throw length: 12.5- 17 m
 Impact throw length: 5.5- 10m

Pressure

Working pressure: 3 - 8 bar
 Recommended pressure: 5 - 6.5 bar

Cleaning Pattern

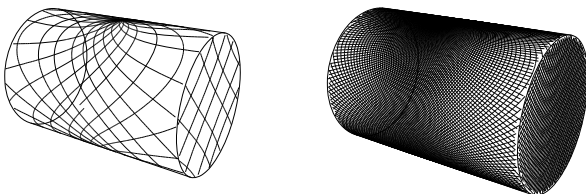

First cycle

Full pattern

The above drawings show the cleaning pattern achieved on a cylindrical horizontal vessel. The difference between the first cycle and the full pattern represents the number of additional cycles available to increase the density of the cleaning.

Certificates

2.2 material certificate, Q-doc, ATEX and EHEDG.



PHYSICAL DATA

Materials

316L (UNS S31603), Duplex steel (UNS N31803), Duplex steel (UNS S21800), PEEK*, PFA* and EPDM*

* FDA compliance 21CFR§177

Welding connection

1" ISO, 1" ANSI/Sch40, 1½" BPE US/SWG, 1½"Dairy, 1½"ANSI/Sch40 or NW40.

Temperature

Max. working temperature: 95°C
 Max. ambient temperature: 140°C

Weight: 6.3 kg

Options

Declaration of Conformity with ATEX approved, Category 1 for installation in zone 0/20.

Caution

Avoid hydraulic shock, hard and abrasive particles in the cleaning liquid, as this can cause increased wear and/or damage of internal mechanisms. In general, a filter in the supply line is recommended. Do not use for gas evacuation or air dispersion. For steaming we refer to the manual.

Standard Design

The choice of nozzle diameters can optimize jet impact length and flow rate at the desired pressure. To maintain the hygienic state of the machine a welding adaptor matching a specific pipe size comes with the machine together with the necessary gaskets. The Toftejorg SaniJet 25 is designed, tested and approved according to EHEDG guidelines on design (guidelines 8), cleanability (guidelines 2) and in-line steam sterilisability (guidelines 5).

Qualification Documentation (Q-doc)

Documentation specification

- Equipment Documentation includes:
- EN 10204 type 3.1 Material Inspection certificate
 - USP Class VI certificate
 - FDA Declaration of Conformity
 - TSE Declaration
 - QC Declaration of Conformity

-
- ATEX
- ATEX approved machine for use in explosive atmospheres.
- Media driven version:
- Catagory 1 for installation in zone 0/20 in accordance to Ex II 1 GD c T 140°C.
- Air driven version:
- Catagory 1 for installation in zone 0/20 in accordance to Ex II 1 GD c T140°C.
- Air driven unit:
- Catagory 2 for installation in zone 1/21 in accordance to Ex II 2 GD c IIC T4 Tamb -20°C to +40°C
-

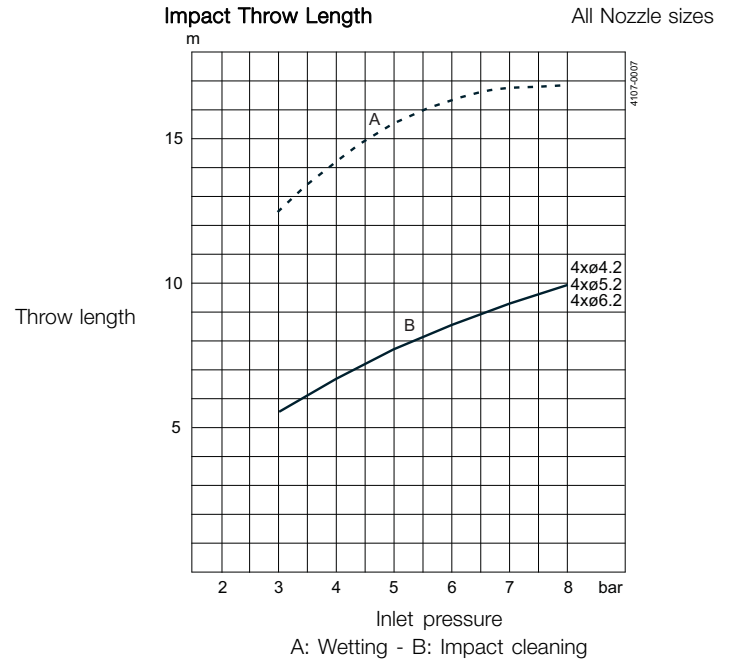
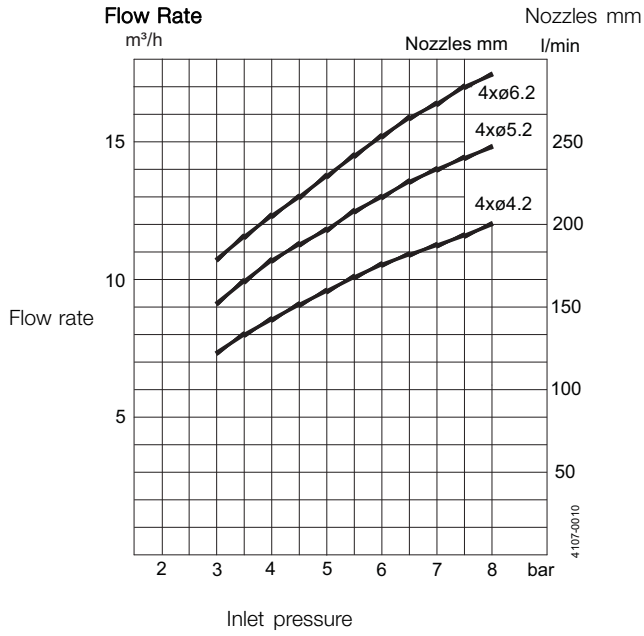

Dimensions (mm)

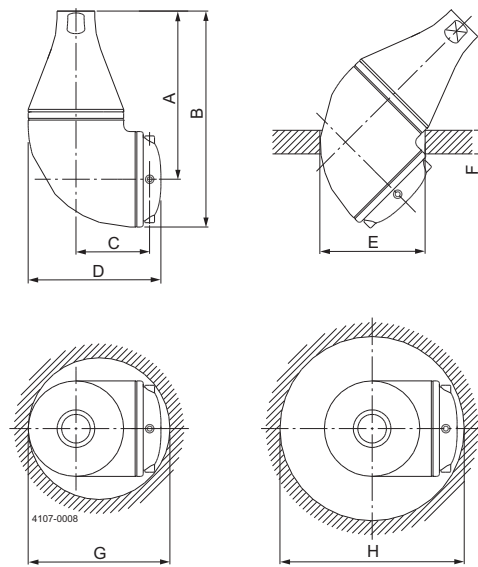

Cleaning Time, Complete Pattern

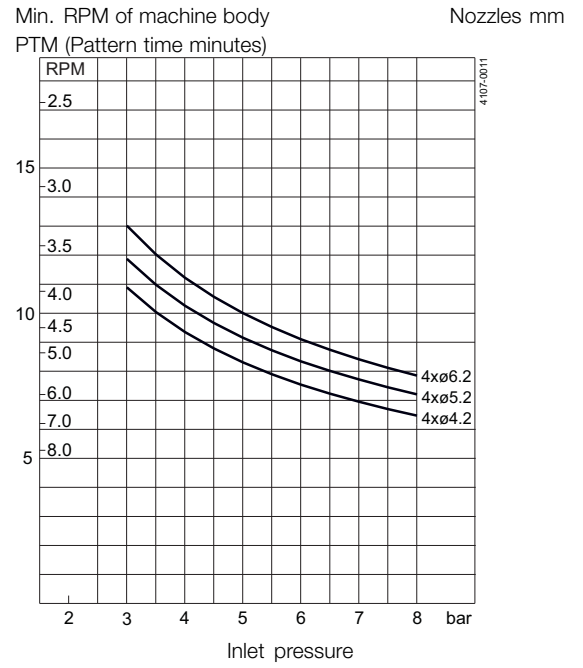

A	B	C	D	E	F	G	H
178	228.5	80	140	ø110	max. 25	ø150	ø195

Alfa Laval reserves the right to change specifications without prior notification.

How to contact Alfa Laval

Contact details for all countries
are continually updated on our website.
Please visit www.alfalaval.com to
access the information direct.