



Alfa Laval SaniJet 20

Meets the Highest Standards in Hygienic Cleaning

Application

The device is designed for use in pharmaceutical, biotechnological, food and dairy processing applications and is suitable for tanks and vessels between 0.5 and 30 m³. It is especially well-suited to processing highly viscous, foaming or thixotropic products and to chemical processing applications where product cross-contamination is unacceptable.

Working principle

The Toftejorg SaniJet 20 is a hygienic, rotary jet head device that cleans in a 3D indexed "Golden Section" pattern. It has an integrated self-cleaning (patented solution) and self-draining downpipe. The drive mechanism is located outside the tank, leaving a minimum of parts inside the vessel or to be submerged into the product. The distance between the tracks of the jets ensures efficient removal of residual product from the tank surface, from the start of the cleaning sequence, allowing for quick jet effective cleaning.

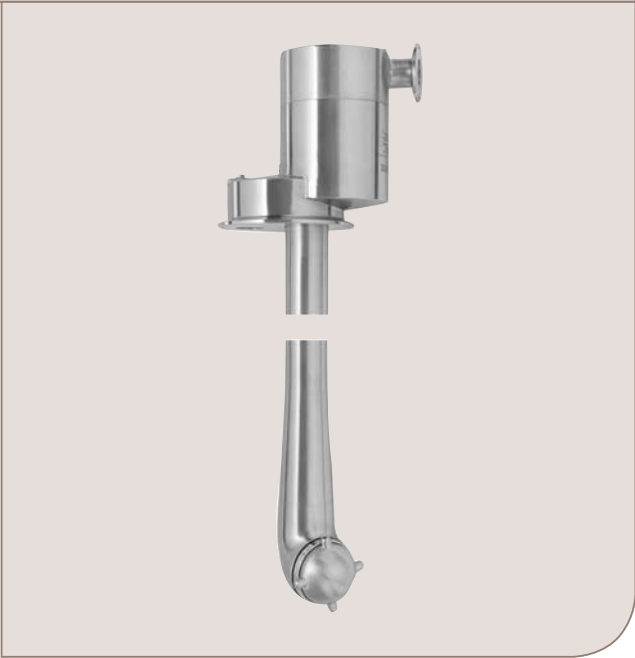

TECHNICAL DATA

Lubricant: Machine: Self-lubricating with the cleaning fluid
Air motor: Can operate non-lubricated

Surface finish:
Product contact parts: Ra 0.8µm
Impact throw length: 1.5 - 4 m
Min. tank opening: 4" Clamp w. rotacheck
3" clamp - rotacheck N/A

Pressure

CIP media working pressure: 3-13 bar
CIP media recommended pressure: . . . 5-8 bar

Air driven

Air quality:
Clean, filtered max. 40µm
Dry, dew point max.: 5°C Non-lubricated possible
Air supply pressure: max. 7 bar
Free air consumption: Max. 2 l/sec. (8 m³/h)
Adjustable speed: 5 - 16 RPM
Cleaning time: 3 - 10 min

Certificates

2.2 material certificate, Q-doc and ATEX.



PHYSICAL DATA

Materials

316L (UNS S31603), PEEK*,
Sealing: EPDM* (standard), FPM* FFKM*
* FDA compliance 21CFR§177

Temperature

Max. working temperature: 90°C
Max. ambient temperature: 140°C

Weight

Media-driven machine: 11 - 18 kg
Air-driven machine: 11.7 - 19.2 kg

Connections

Inlet connection: Clamp: 1" ISO 2852
Tank connection: Clamp: 4" ISO 2852
Tank connection: Clamp: 3" ISO 2852

Note: 3" Tank connection has no possibility of integrated rotacheck.

Options

- Electronic rotation sensor to verify 3D coverage
- Improved surface finish
- 3.1 certification for metallic parts by request
- With FFKM or FPM seal ring
- ATEX

Caution

Avoid hydraulic shock, hard and abrasive particles in the cleaning liquid, as this can cause increased wear and/or damage of internal mechanisms. In general, a filter in the supply line is recommended. Do not use for gas evacuation or air dispersion. For steaming we refer to the manual.

Standard Design

The Toftejorg SaniJet 20 is available in media-driven or air-driven version. Air-driven versions are equipped with a magnetic clutch for leakage-proof transmission. The air motor provides an effective drive for low flow machines in rough environments and for use in explosive hazard zones, provided it is installed according to safety instructions. The air motor has variable speed to adjust cleaning intensity.

Cleaning Pattern

Example - 2xø3.8LS

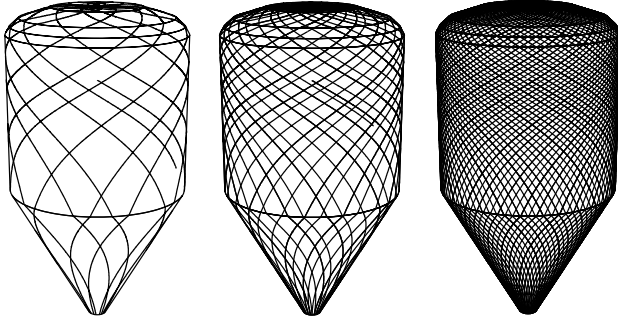

0.8 min.

2.3 min.

6.0 min.

Flow Rate (Media & Air driven)

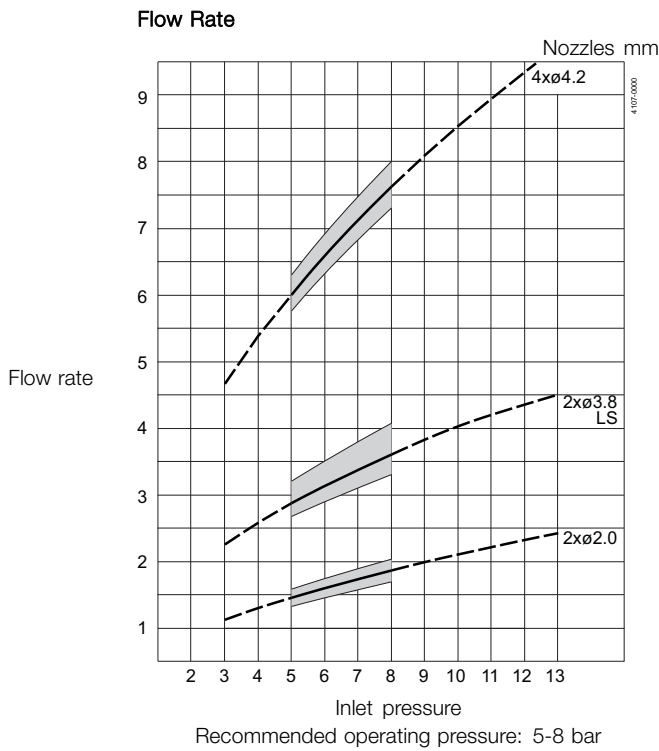

Qualification Documentation (Q-doc)

Documentation specification

Equipment Documentation includes:

- EN 10204 type 3.1 Material Inspection certificate
- USP Class VI certificate
- Q-doc - FDA Declaration of Conformity
- TSE Declaration
- QC Declaration of Conformity

ATEX approved machine for use in explosive atmospheres.

Media driven version:

Category 1 for installation in zone 0/20 in accordance to Ex II 1 GD c T 140°C.

Air driven version:

ATEX Category 1 for installation in zone 0/20 in accordance to Ex II 1 GD c T140°C.

Air driven unit:

Category 2 for installation in zone 1/21 in accordance to Ex II 2 GD c IIC T4 Tamb -20°C to +40°C

Impact Throw Length, Media Driven

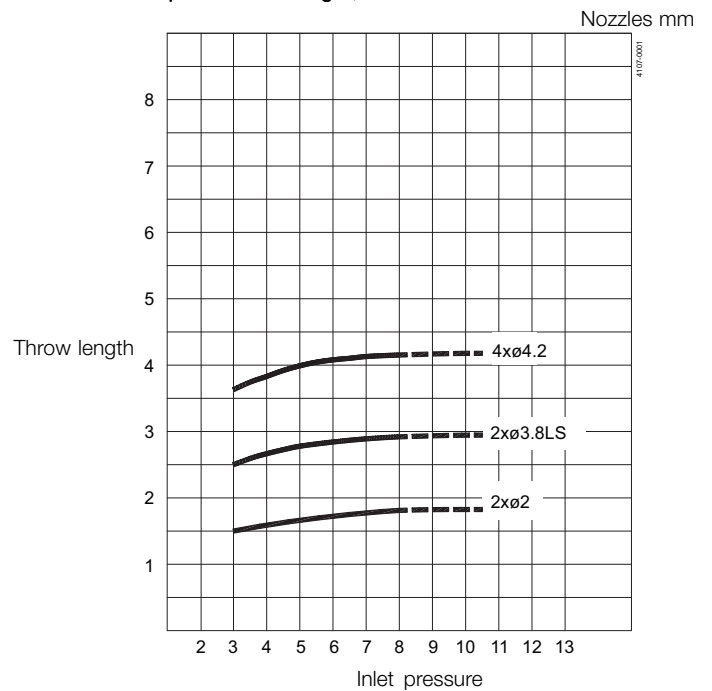

Dimensions (mm), Media Driven

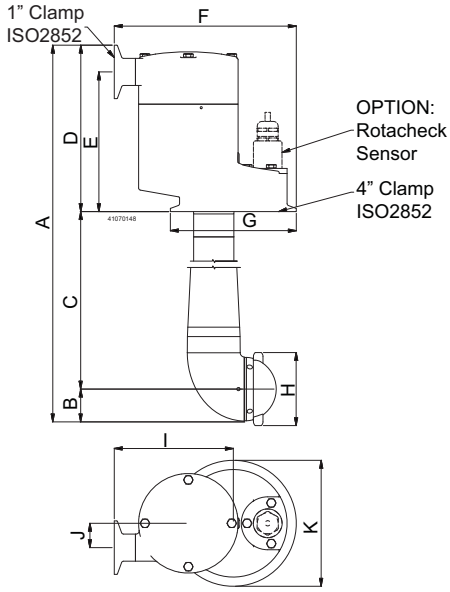

Cleaning Time, Complete Pattern, Media driven

Min. RPM of machine body
PTM (Pattern time minutes)

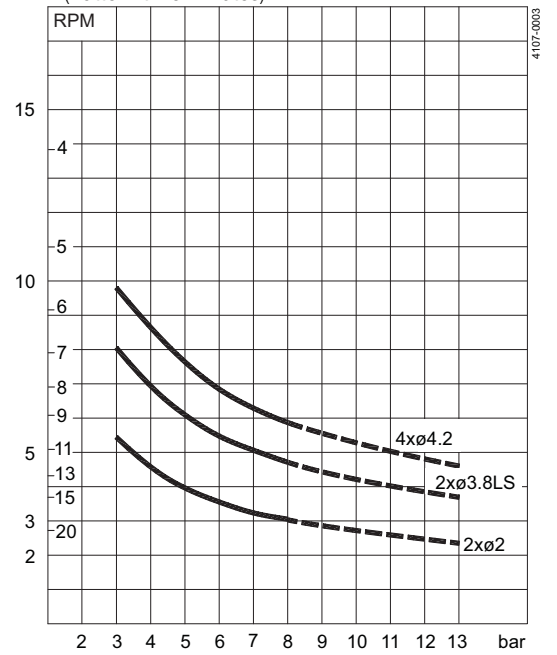

Inlet pressure

	A	B	C	D	E	F	G	H	I	J	K
mm	537 - 687 - 887 - 1187 - 1387 - 1687	31	350 - 500 - 700 - 1000 - 1200 - 1500	157.25	132	172	Ø119	Ø69	112.5	23	Ø119

Dimensions (mm), Air Driven

Impact Throw Length, Air Driven

Nozzles mm

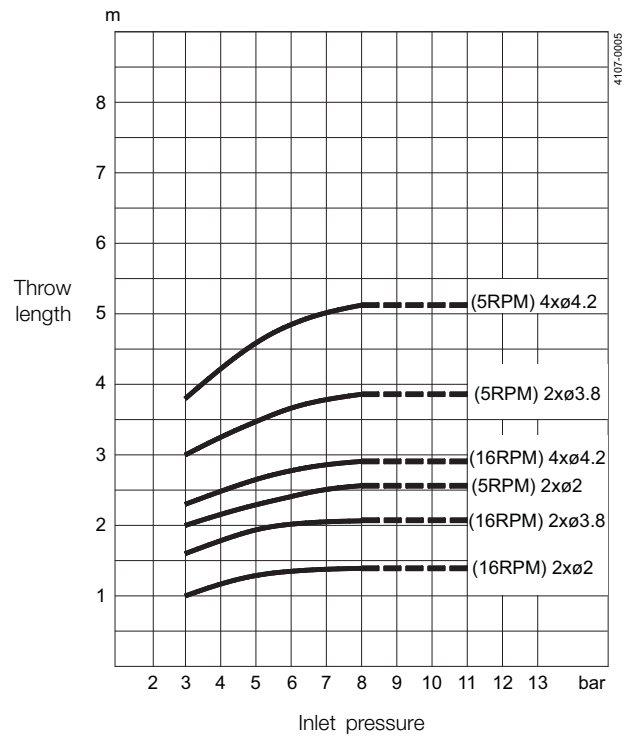
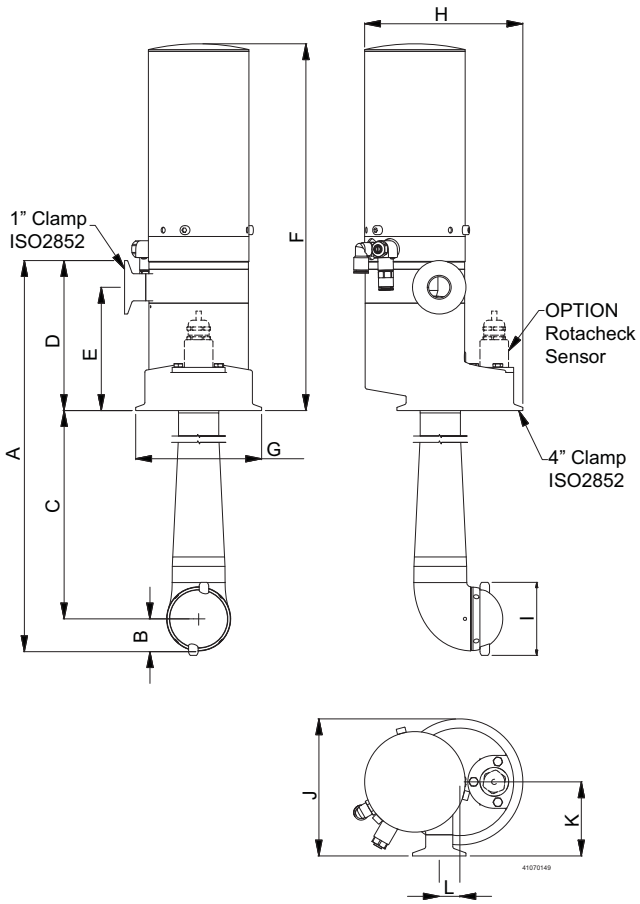

	A	B	C	D	E	F	G	H	I	J	K	L
mm	523 - 673 - 873 - 1173 - 1376 - 1673	31	360 - 500 - 700 - 1000 - 1200 - 1500	142	117	340	Ø119	168	Ø69	130	70	19.5

TRAX simulation tool

TRAX is a unique software that simulates how the Toftejorg SaniJet 20 performs in a specific tank or vessel. The simulation gives information on wetting intensity, pattern mesh width and cleaning jet velocity. This information is used to determine the best location of the tank cleaning machine and the correct combination of flow, time and pressure to implement. A TRAX demo containing different cleaning simulations covering a variety of applications can be used as reference and documentation for tank cleaning applications. A TRAX simulation is free and available upon request.

Wetting Intensity

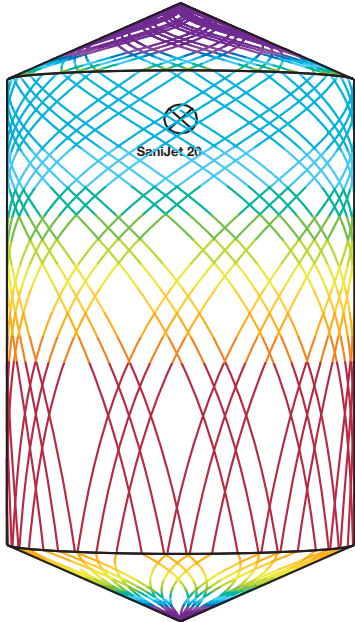
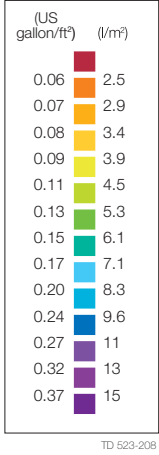

D2m H3m, Toftejorg SaniJet 20, 4 x ø4.2 mm, Time = 1.7 min., Water consumption = 171 l

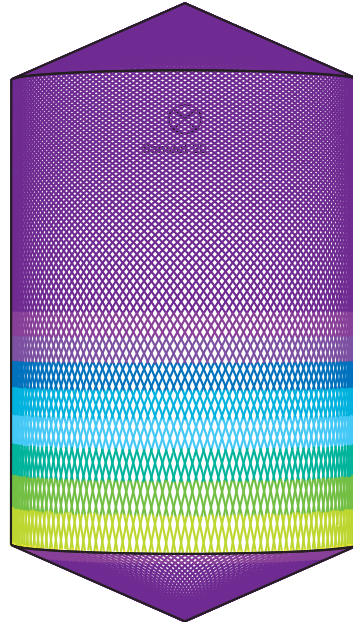

D2m H3m, Toftejorg SaniJet 20, 4 x ø4.2 mm, Time = 7.6 min., Water consumption = 763 l

Cleaning Pattern, the Golden Section

Toftejorg SaniJet 20 operates according to the patented Golden Section cleaning pattern (EP-Patent No.: 0495883, US-Patent No.: 5,279,675), which is unique in building up a uniform pattern. The pattern starts very coarse and refines itself in a step-less way by laying out the tracks approximately in the middle of the two most distant tracks already made. This means that the jets always clean the areas containing the most remaining product, and thereby remove as much deposit as possible in the shortest possible time. In some instances, this method of cleaning can even render a complete cleaning pattern unnecessary. The Golden Section is the most suitable cleaning pattern for an effective pre-rinse.

Golden Section Cleaning Pattern Traditional Cleaning Pattern

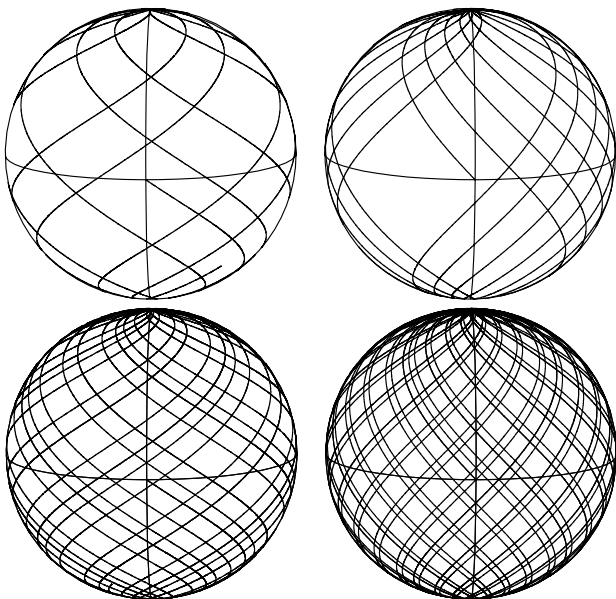

Alfa Laval reserves the right to change specifications without prior notification.

How to contact Alfa Laval

Contact details for all countries are continually updated on our website. Please visit www.alfalaval.com to access the information direct.